

# UNDETECTABLE

2000 / 1000 MODELS

## INSTALLATION INSTRUCTIONS & RECOMMENDED PROCEDURES

### WARNING & BI-COLOR LED(S)

(MODELS: K40-2000/1000)

1. Consult with vehicle owner about LED location. For best visibility, choose a mounting location as close to the vehicle gauges as possible.
2. Check for proper clearance behind the area where the LED(s) will be installed (approximately 1") and drill a 3/16" hole in the chosen location for the LED(s). K40-2000 models require the mounting of a second LED for rear radar warnings (see diagram A1).
3. If using the optional bi-color city/highway LED, choose a mounting location in the dashboard area that is below the driver's line of sight.
4. Check for proper clearance behind the area (approximately 1"), and drill a 19/64" hole for the bi-color LED location. Insert the LED into the drilled location and fasten it in place with the provided barrel fastener (see diagram A2).
5. Route all LED wires under the dash per diagram A3, and connect according to the separately enclosed block wiring diagram.

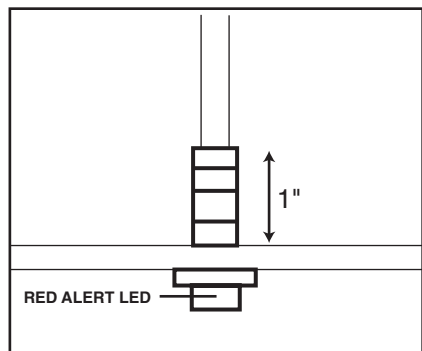

DIAGRAM A1

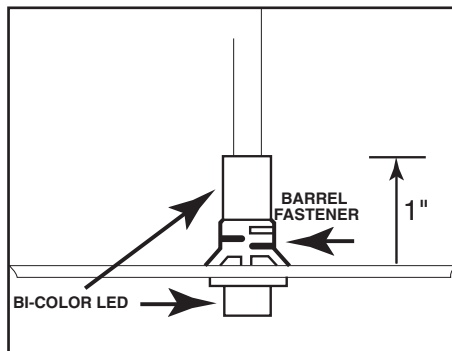

DIAGRAM A2

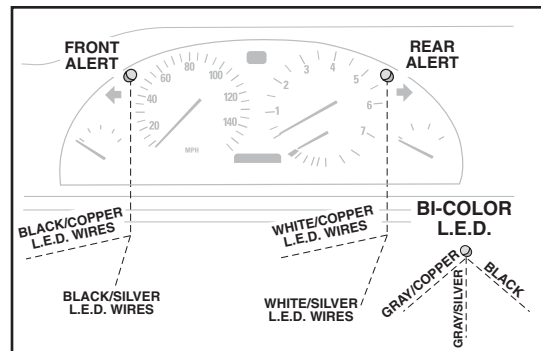

DIAGRAM A3

### PIEZO SPEAKERS

(MODELS: K40-2000/1000)

1. Use the provided double stick "O" ring tape to mount the piezo speakers.
2. For maximum audio output and concealment, mount the front piezo speaker in the driver's left air vent. Mount the rear piezo speaker in the driver's right air vent.
3. Route the piezo speaker zip cord wires through or under the dash and connect according to the separately enclosed block wiring diagram (see diagram B1).

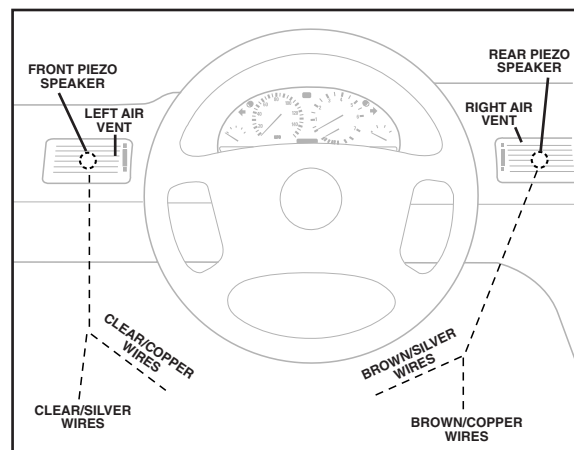

DIAGRAM B1

# WARNING POD(S)

(MODELS: K40-2000P/1000P)

**NOTE:** For added installation convenience, Warning Pods contain both a warning LED and piezo speaker.

1. Consult with vehicle owner about Pod location. For best visibility, choose a mounting location as close to the vehicle's gauges as possible.
2. Before mounting the Warning Pod(s), clean both the Pod surface and desired mounting location on the dash with isopropyl alcohol.
3. Position the Warning Pod(s) on the dash with the provided double stick "O" ring tape. K40-2000P models require the mounting of a second Pod for rear radar warnings.
4. Route the black cables from the Warning Pod(s) through or under the dash per diagram C1, and connect according to the separately enclosed block wiring diagram.

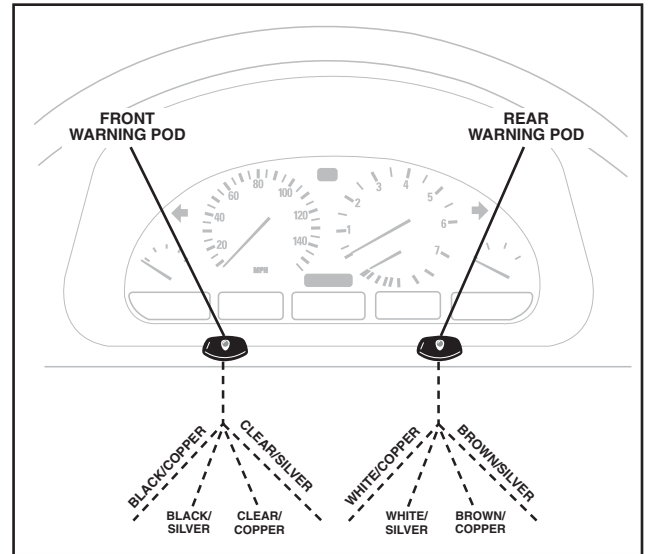

DIAGRAM C1

# FRONT RADAR RECEIVER

(ALL MODELS)

**NOTE:** All radar receivers can be mounted behind plastic, rubber, or fiberglass up to 1/4" thick. Do not mount receivers behind metal, carbon fiber, or chromed plastic.

1. Choose a mounting location in the front of the vehicle that is not obstructed by any metal, carbon fiber, or chromed plastic. The radar receiver can be mounted horizontally or vertically, provided the arrows are pointing forward, towards the road ahead.
2. Mount the radar receiver to the vehicle's structure using the supplied screws or wire ties (see diagram D1).

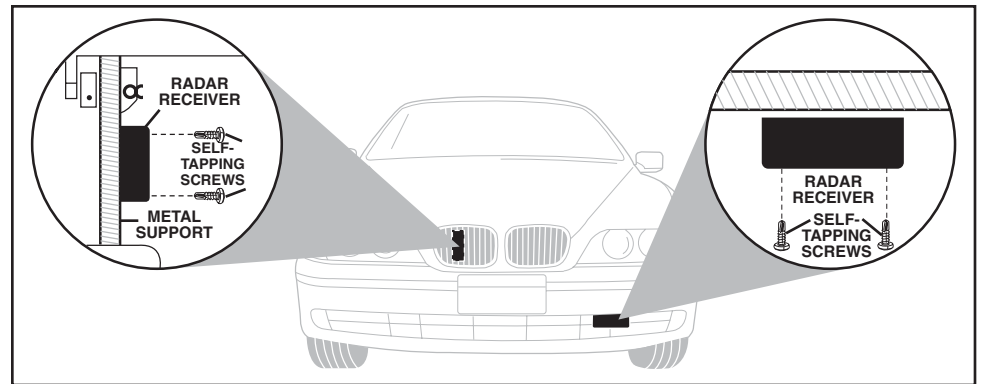

DIAGRAM D1

3. Connect the radar receiver to the 10' black radar receiver cable. Align slot on cable plug to the notch on radar receiver socket, slide the locking ring forward over the socket, and turn ring clockwise 1/4 turn to engage safety lock (see diagram D2).
4. Route and affix the radar receiver cable along the inner fender in the engine compartment to the firewall using the provided wire straps.
5. Route the radar receiver cable through a factory rubber grommet on the firewall and into the passenger compartment (see diagram D3). Connect wires according to the separately enclosed block wiring diagram.

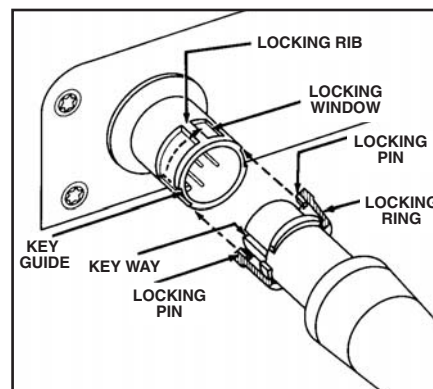

DIAGRAM D2

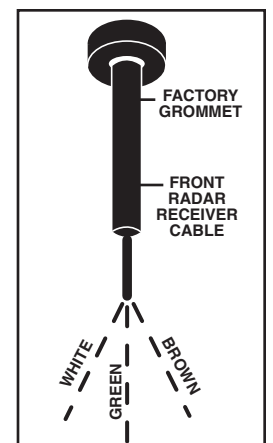

DIAGRAM D3

# REAR RADAR RECEIVER

(MODELS: K40-2000/2000P)

**NOTE:** *All radar receivers can be mounted behind plastic, rubber, or fiberglass up to 1/4" thick. Do not mount behind metal, carbon fiber, or chromed plastic.*

1. Choose a mounting location in the rear of the vehicle that is not obstructed by any metal, carbon fiber, or chromed plastic. The radar receiver can be mounted horizontally or vertically, provided the arrows are pointing to the rear, towards the road behind the vehicle.
2. Mount the radar receiver to the vehicle's structure using the supplied screws or wire ties (see diagram E1).
3. Connect the radar receiver to the 25' black radar receiver cable. Align slot on cable plug to the notch on radar receiver socket, slide the locking ring forward over the socket, and turn ring clockwise 1/4 turn to engage safety lock (see diagram E2).
4. Route the rear radar receiver cable into the trunk through a factory grommet.
5. If a factory grommet is not available, use the provided strain relief:
  - a. Choose a location in the trunk compartment as close to the radar receiver as possible.
  - b. Drill a 1/2" hole into the chosen location for the strain relief.

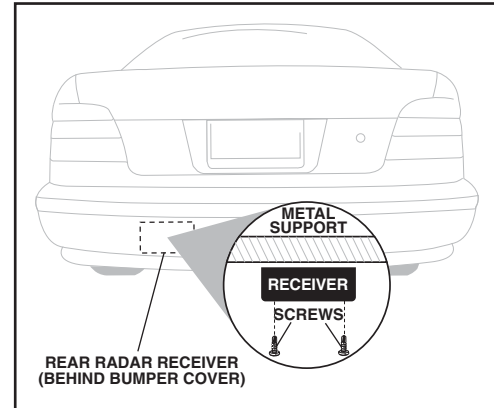

DIAGRAM E1

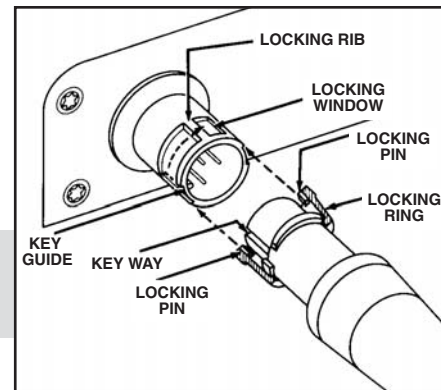

DIAGRAM E2

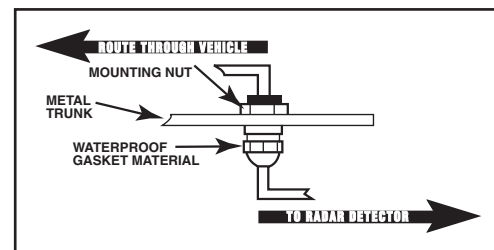

DIAGRAM E3

## CAUTION!

**Do not drill into the trunk until you know what is on both sides of the drilling area. Watch for cables, spare tires, and gas tank.**

- c. Install the strain relief and tighten the mounting nut securely (see diagram E3)
  - d. Route the rear radar receiver cable through the strain relief, leaving a little slack in the receiver cable.
  - e. Tighten the waterproof gasket nut to create a water proof seal.
6. Route the rear radar receiver cable through the trunk, into the passenger compartment along the driver's side, and under the dash. Connect wires according separately enclosed block wiring diagram.

# VOLUME CONTROL MODULE

(ALL MODELS)

1. Choose a mounting location that's accessible to the driver in the dashboard area or in the vehicle's center console that will not obstruct or block any moving parts.

## CAUTION!

**Before drilling, make sure there is enough clearance for the Volume Control Module behind the chosen mounting location (approximately 3 1/4").**

2. Drill a 5/16" hole.
3. Mount the Volume Control Module with the lock washer and nuts, and push the filter and volume adjustment knobs onto the module shaft (see diagram F1).
4. Route the Volume Control Module cable under the dash and connect wires according to the separately enclosed block wiring diagram.

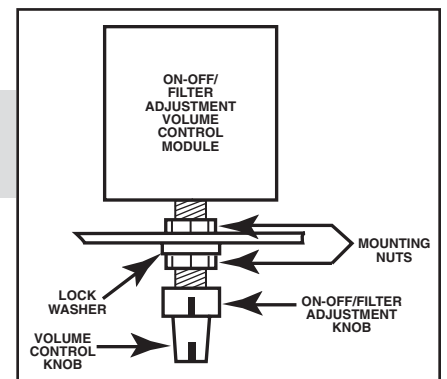

DIAGRAM F1

